

# **PRODUCT SPECIFICATION** **FOR LCD MODULE**

**Revision:** 1.0

**Model No:** LS0128I06-S-V2

**Module Type:** COG+FPC+B/L

<b>APPROVED SIGNATURE</b>
---------------------------

- Approved Product Specification only
- Approved Product Specification and Samples

<b><u>Prepared By</u></b>	<b><u>Checked By</u></b>	<b><u>Approved By</u></b>

## Contents

目录

1. General Description .....	3
2. Physical Features .....	3
3. Mechanical Specification .....	3
4. Outline Dimension .....	4
5. Absolute Maximum Ratings .....	5
6. Electrical Characteristics .....	5
7. Module Function Description .....	6
8. Electro-Optical Characteristics .....	9
9. Records Of Version .....	12

# 1. General Description

LS0128I06-S-V2 is a transmissive type a-Si TFT-LCD (amorphous silicon thin film transistor liquid crystal display) module, which is composed of a TFT-LCD panel, a driver circuit and a backlight unit. The panel size is 1.28 inch and the resolution is 240(RGB)\*240, the panel can display up to 262k colors.

# 2. Physical Features

Display Mode	TFT-LCD Module
	Active matrix TFT, Transmissive type
Display Format	Graphic 240(RGB)×240 Dot-matrix
Input Data	4-line serial interface
Viewing Direction (Grayscale Inversion)	Free (IPS)
Drive	ST77912

# 3. Mechanical Specification

Item	Specification	Unit
Module size (H×V×D)	35.6 ×37.74 ×2.1	mm
Number of dots	240(RGB) ×240	pixel
Active area (H×V)	32.4×32.4	mm



## 5. Absolute Maximum Ratings

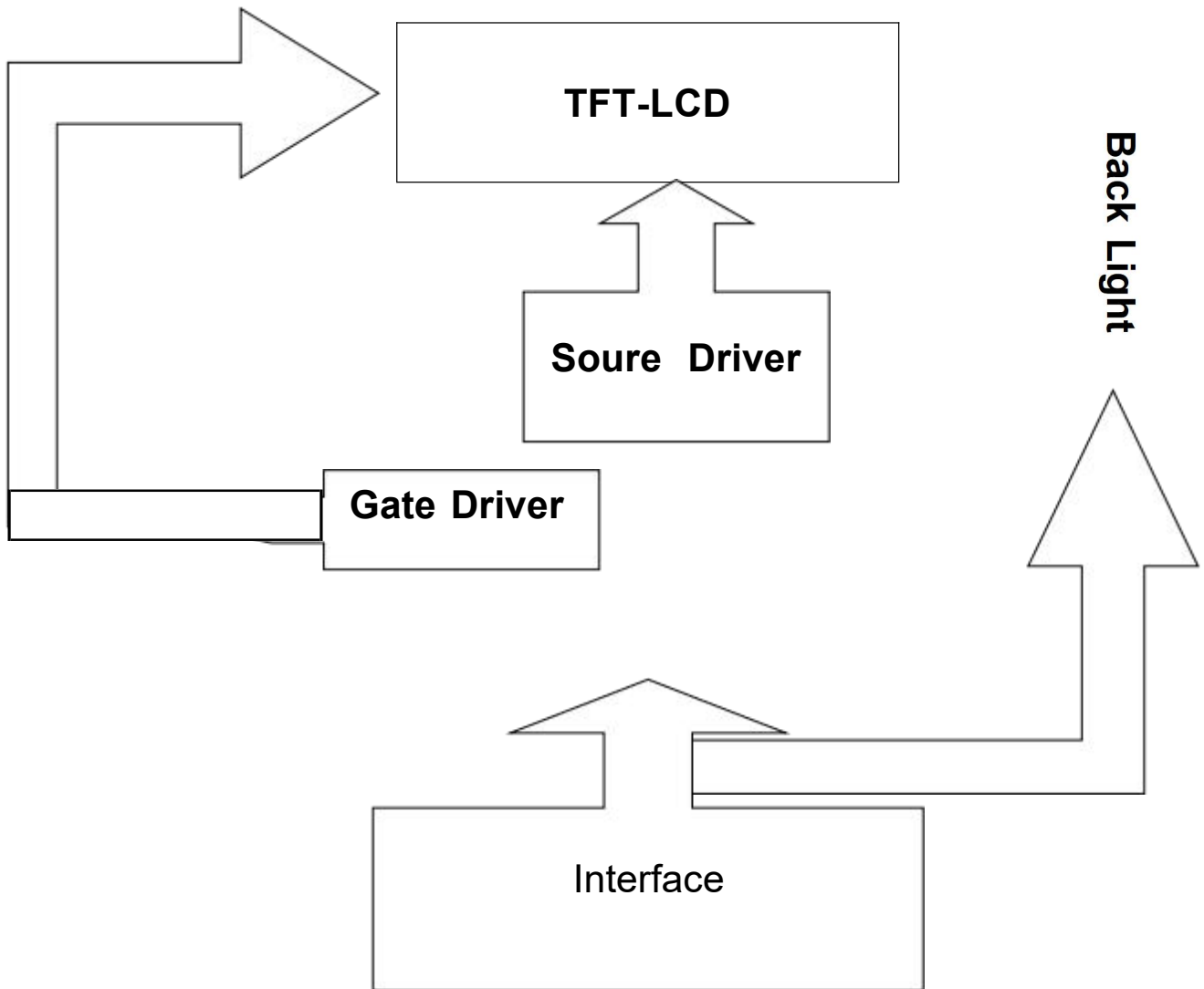
Item	Symbol	Min	Max	Unit	Remark
Supply voltage	VCC	-0.3	4.6	V	Note1 Note2
Supply voltage	IOVCC	-0.3	4.6	V	
Operating temperature	TOPR	-10	60	°C	
Storage temperature	TSTR	-20	70	°C	

## 6. Electrical Characteristics

Item	Symbol	Rating			Unit	Remark	
		Min	Typ	Max			
Supply voltage	VCC	2.65	2.8	3.3	V	Note1	
Supply voltage	IOVCC	1.65	1.8	3.3	V		
Input Voltage	L level	VIL	0	---	0.3*IOVCC		V
	H level	VIH	0.7*IOVCC	---	IOVCC		V

## 7. Module Function Description

### 7-1. Block Diagram Of LCM



## 7-2. Pin Description

PIN NO.	Symbol	I/O	Description
1	LEDK	P	Power for LED backlight cathode
2	GND	P	Ground
3	TE	O	Tearing effect output pin to synchronize MPU to frame writing
4	SDA	I/O	Serial data input/output PIN
5	RS	I	Command and Data select pin
6	SCL	I	Serial clock pin
7	CS	I	Chip select pin
8	RESET	I	Reset pin.
9	IOVCC1.8V	P	power supply
10	VCC2.8V	P	power supply
11	VCC2.8V	P	power supply
12	GND	P	Ground
13	GND	P	Ground
14	LEDA	P	Power for LED backlight anode
15	LEDA	P	Power for LED backlight anode

## 7-3 Timing Characteristics

### 7.4.3 Serial Interface Characteristics (4-line serial):

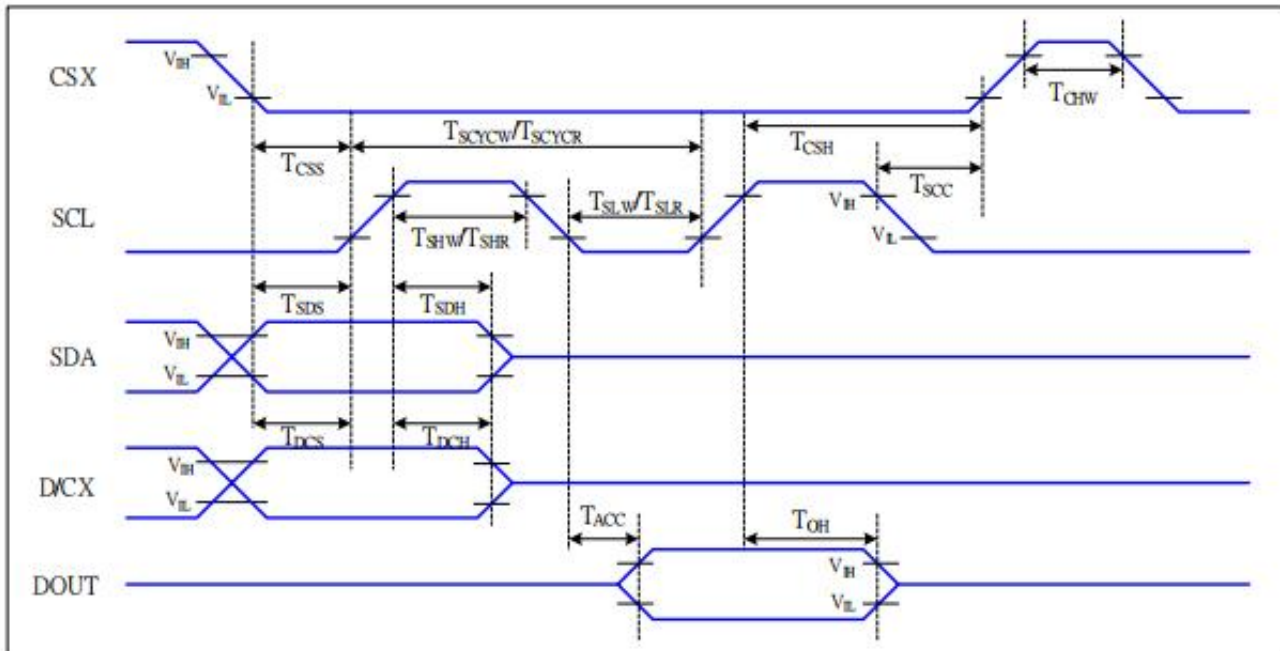


Figure 5 4-line serial Interface Timing Characteristics

VDDI=1.65 to 3.3V, VDD=2.65 to 3.3V, GND=RGND=0V, Ta=25°C

Signal	Symbol	Parameter	MIN	MAX	Unit	Description
CSX	T <sub>CSS</sub>	Chip select setup time (write)	15		ns	
	T <sub>CSH</sub>	Chip select hold time (write)	15		ns	
	T <sub>CSS</sub>	Chip select setup time (read)	60		ns	
	T <sub>SCC</sub>	Chip select hold time (read)	65		ns	
	T <sub>CHW</sub>	Chip select "H" pulse width	40		ns	
SCL	T <sub>SCYCW</sub>	Serial clock cycle (Write)	16		ns	-write command & data ram
	T <sub>SHW</sub>	SCL "H" pulse width (Write)	7		ns	
	T <sub>SLW</sub>	SCL "L" pulse width (Write)	7		ns	
	T <sub>SCYCR</sub>	Serial clock cycle (Read)	150		ns	-read command & data ram
	T <sub>SHR</sub>	SCL "H" pulse width (Read)	60		ns	
	T <sub>SLR</sub>	SCL "L" pulse width (Read)	60		ns	
D/CX	T <sub>DCS</sub>	D/CX setup time	7		ns	
	T <sub>DCH</sub>	D/CX hold time	7		ns	
SDA (DIN)	T <sub>SDS</sub>	Data setup time	7		ns	
	T <sub>SDH</sub>	Data hold time	7		ns	
DOUT	T <sub>ACC</sub>	Access time	10	50	ns	For maximum CL=30pF
	T <sub>OH</sub>	Output disable time	15	50	ns	For minimum CL=8pF

Table 6 4-line serial Interface Characteristics

## 8. Electro-Optical Characteristics

Item		Symbol	Condition	Min.	Typ.	Max.	Unit	Remark
Response time		Tr +Tf	$\theta_x = \theta_y = 0$	---	30	40	ms	Note 1
Contrast Ratio		CR		600	800	---	---	Note 2
Transmittance		T%		3.0	3.8	---	%	
Color Chromaticity (CIE1931)	White	W x	$\theta_x = \theta_y = 0$	---	TBD	---	---	
		W y		---	TBD	---	---	
Viewing angle	$\theta_T$		CR > 10	80	---	---	Deg.	Note 3
	$\theta_B$			80	---	---		
	$\theta_L$			80	---	---		
	$\theta_R$			80	---	---		

### Note1. Measuring Condition

- (1) Measuring surrounding: dark room
- (2) Ambient temperature: Ta=25°C
- (3) 15min. warm-up time

Note2. Response time is the time required for the display to transition from Black to White (Rise Time, Tr) and from White to Black (Decay Time, Tf). The measurement instrument is DMS-803. For more information, please refer to FIG 1 and FIG 2.

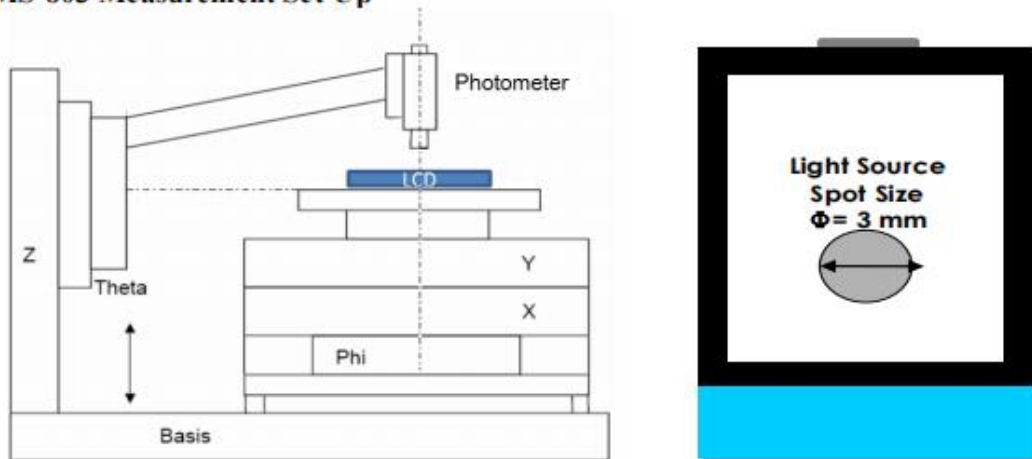
Note3. Contrast Ratio (CR) is defined mathematically as below. Measured at the center point of panel by DMS-803, please refer to FIG 1

$$\text{Contrast Ratio} = \frac{\text{Surface Luminance with all white pixels}}{\text{Surface Luminance with all black pixels}}$$

Note4. Viewing angle is the angle at which the contrast ratio is greater than 10(CR≥10:1). The measurement instrument is DMS-803. For more information, please refer to FIG 1 and FIG 3.

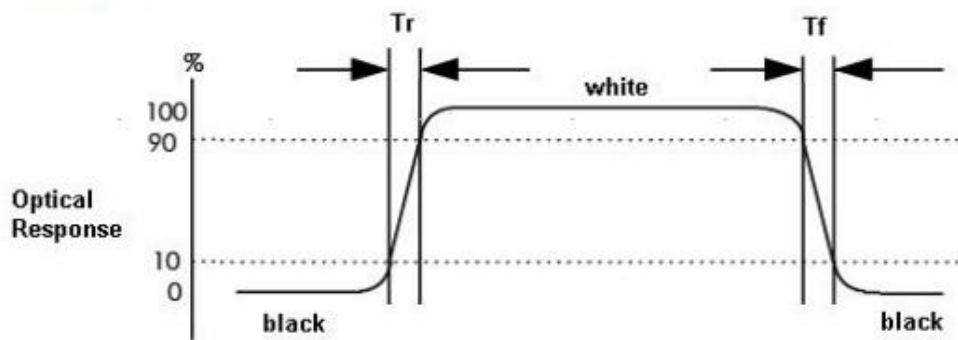
Note5. CIE (x, y) chromaticity for CF only, measured with Olympus MHL-450 under C light.

**FIG. 1 DMS-803 Measurement Set-Up**

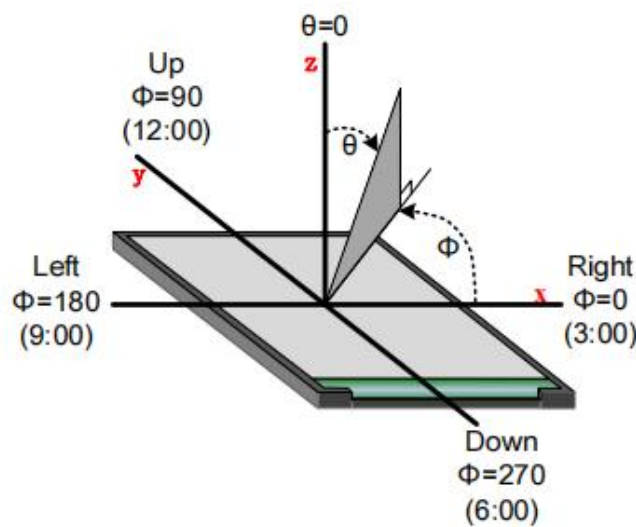


**FIG. 2 The definition of Response Time**

The response time is defined as the following figure and shall be measured by switching the input signal for “black” and “white”. This definition is valid for a normally black display. For a normally white display the opposite definition applies.

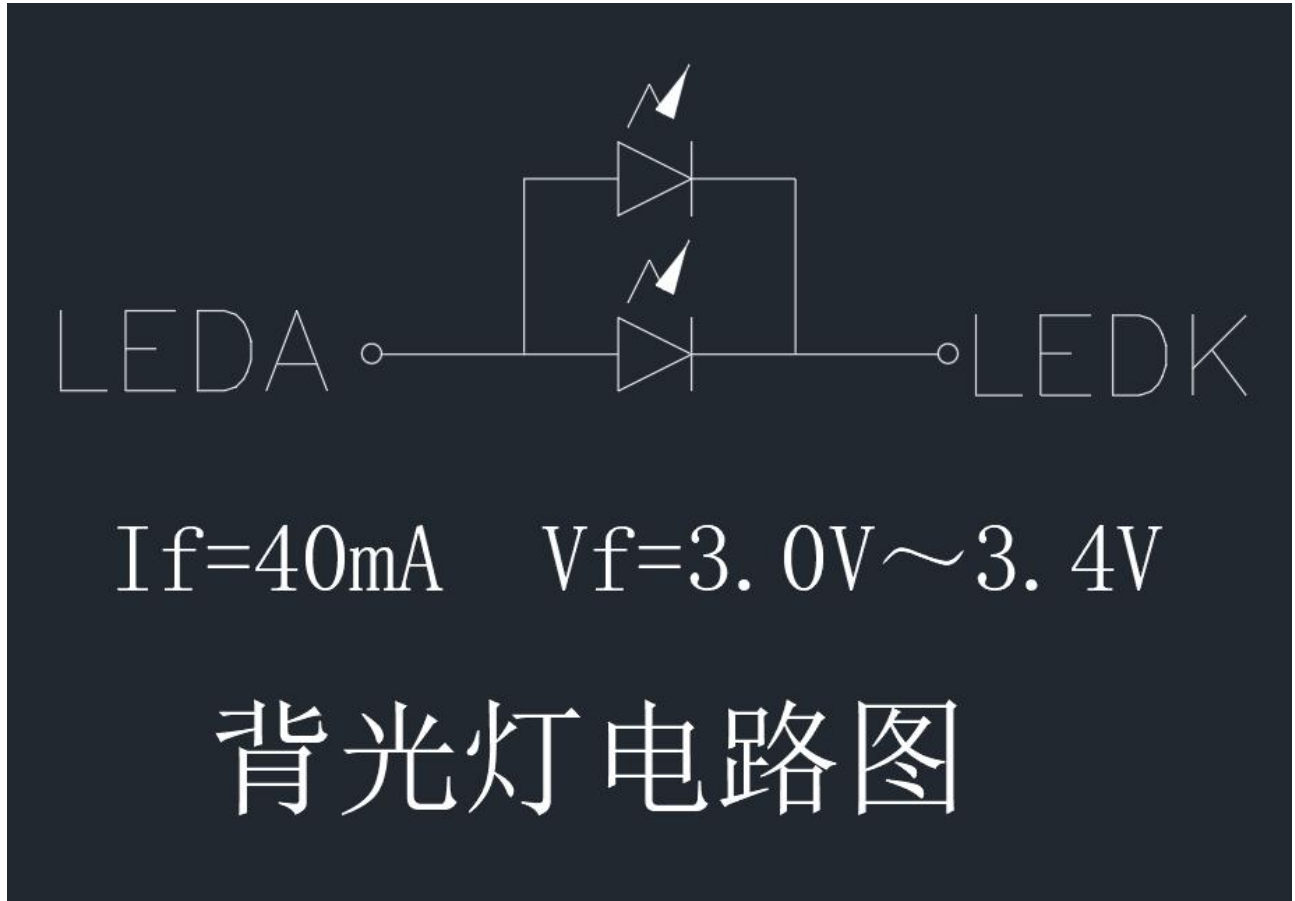


**FIG. 3 The definition of viewing angle**



**Note(4) Backlight circuit**

a. Light Source: LED\*2(White)



## 9.Records Of Version

<b>Version</b>	<b>Revise Date</b>	<b>Page</b>	<b>Content</b>
00		ALL	New released