

PRODUCT SPECIFICATION **FOR LCD MODULE**

Revision: 1.0

Model No: LS019I05-S-V1

Module Type: COG+FPC+B/L

APPROVED SIGNATURE

- Approved Product Specification only
- Approved Product Specification and Samples

<u>Prepared By</u>	<u>Checked By</u>	<u>Approved By</u>

Contents

目录

1. General Description	3
2. Physical Features	3
3. Mechanical Specification	3
4. Outline Dimension	4
5. Absolute Maximum Ratings	5
6. Electrical Characteristics	5
7. Module Function Description	6
8. Electro-Optical Characteristics	9
9. Records Of Version	12

1. General Description

LS019I05-S-V1 is a transmissive type a-Si TFT-LCD (amorphous silicon thin film transistor liquid crystal display) module, which is composed of a TFT-LCD panel, a driver circuit and a backlight unit. The panel size is 1.9 inch and the resolution is 170(RGB)*320, the panel can display up to 262k colors.

2. Physical Features

Display Mode	TFT-LCD Module
	Active matrix TFT, Transmissive type
Display Format	Graphic 170(RGB)×320 Dot-matrix
Input Data	SPI
Viewing Direction (Grayscale Inversion)	IPS
Drive	ST7789P3

3. Mechanical Specification

Item	Specification	Unit
Module size (H×V×D)	25.8 ×49.73×2.07	mm
Number of dots	170(RGB) × 320	pixel
Active area (H×V)	22.695×42.72	mm

4. Outline Dimension

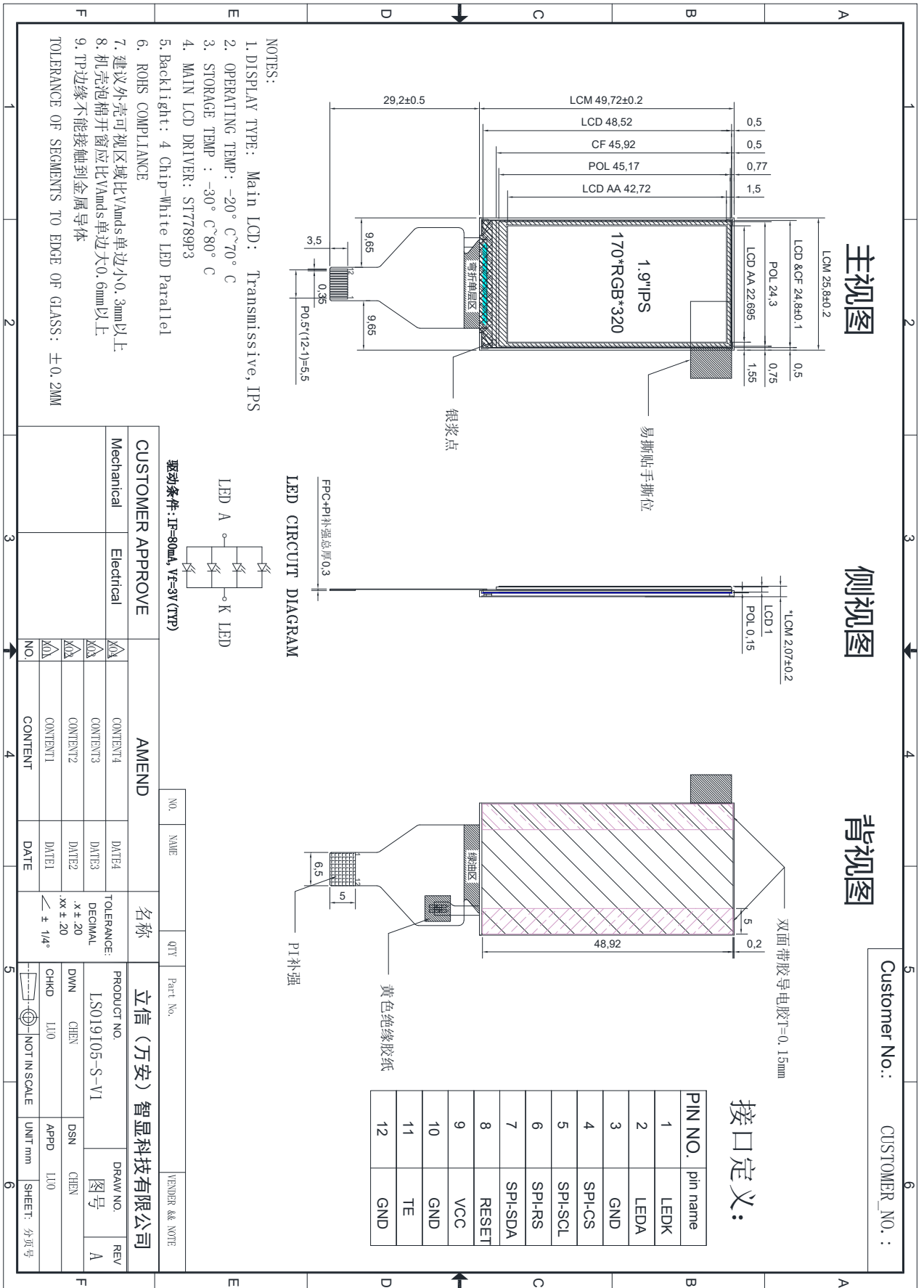

5. Absolute Maximum Ratings

Item	Symbol	Min	Max	Unit	Remark
Supply voltage	VCC	-0.3	4.6	V	Note1 Note2
Supply voltage	IOVCC	-0.3	4.6	V	
Operating temperature	TOPR	-20	70	°C	
Storage temperature	TSTR	-30	80	°C	

6. Electrical Characteristics

Item	Symbol	Rating			Unit	Remark	
		Min	Typ	Max			
Supply voltage	VCC	2.4	2.8	3.3	V	Note1	
Supply voltage	IOVCC	1.65	1.8	3.3	V		
Input Voltage	L level	VIL	0	---	0.3*IOVCC		V
	H level	VIH	0.7*IOVCC	---	IOVCC		V

7. Module Function Description

7-1. Block Diagram Of LCM

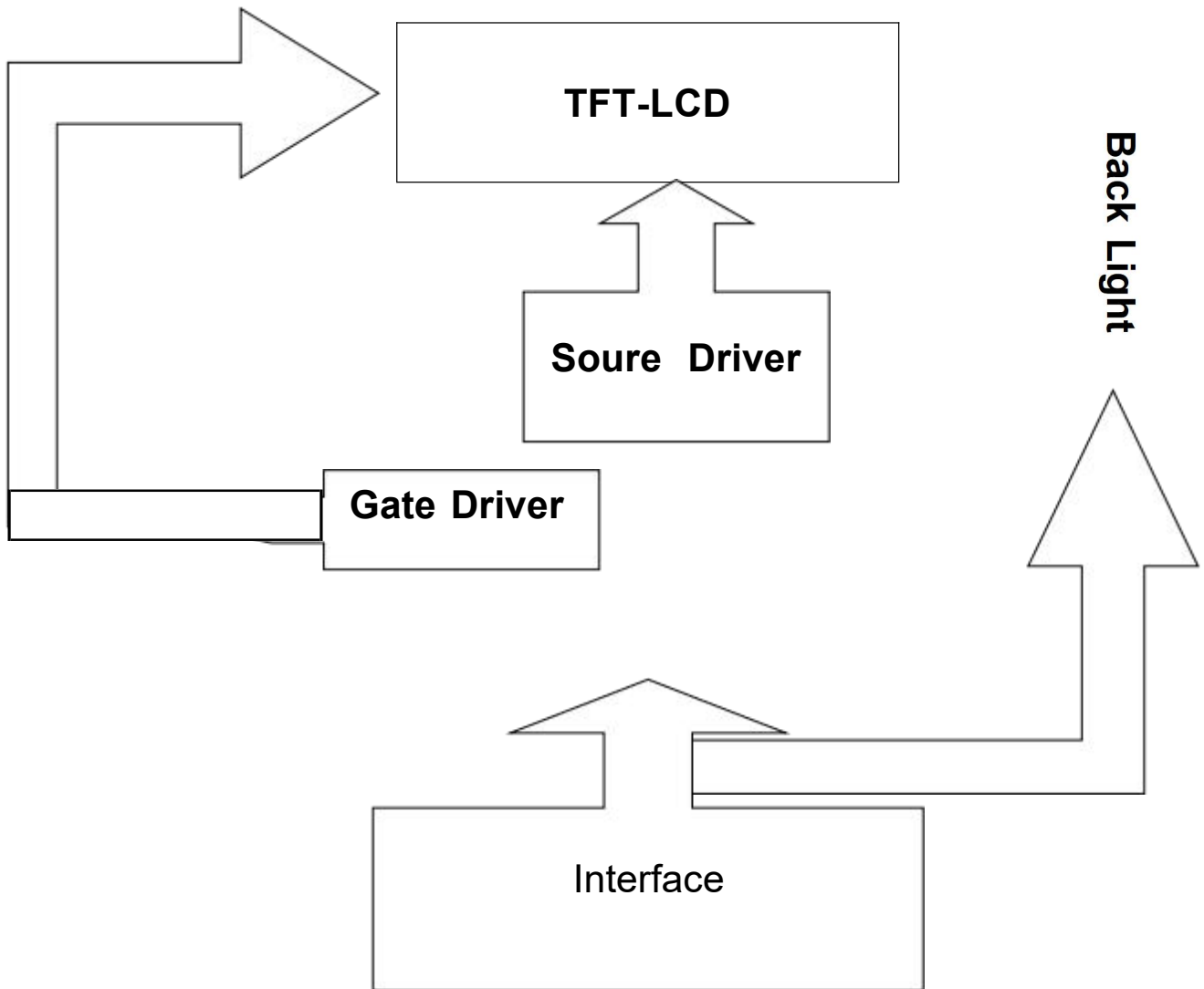

7-2. Pin Description

PIN NO.	Symbol	I/O	Description
1	LEDK	P	Power for LED backlight cathode
2	LEDA	P	Power for LED backlight anode
3	GND	P	Ground
4	SPI_CS	I	Chip select pin
5	SPI_SCL	I	Serial clock pin
6	SPI_RS	I	Command and Data select pin
7	SPI_SDA	I/O	Serial data input/output PIN
8	RESET	I	Reset pin.
9	VCC	P	power supply
10	GND	P	Ground
11	TE	O	Tearing effect signal is used to synchronize MCU to frame memory writing
12	GND	P	Ground

8. Electro-Optical Characteristics

Item		Symbol	Condition	Min.	Typ.	Max.	Unit	Remark
Response time		Tr +Tf	$\theta_x = \theta_y = 0$	---	30	40	ms	Note 1
Contrast Ratio		CR		700	900	---	---	Note 2
Transmittance		T%		3.5	4.3	---	%	
Color Chromaticity (CIE1931)	White	W x	$\theta_x = \theta_y = 0$	---	0.302	---	---	
		W y		---	0.325	---	---	
Viewing angle	θ_T		CR > 10	80	---	---	Deg.	Note 3
	θ_B			80	---	---		
	θ_L			80	---	---		
	θ_R			80	---	---		

Note1. Measuring Condition

- (1) Measuring surrounding: dark room
- (2) Ambient temperature: Ta=25°C
- (3) 15min. warm-up time

Note2. Response time is the time required for the display to transition from Black to White (Rise Time, Tr) and from White to Black (Decay Time, Tf). The measurement instrument is DMS-803. For more information, please refer to FIG 1 and FIG 2.

Note3. Contrast Ratio (CR) is defined mathematically as below. Measured at the center point of panel by DMS-803, please refer to FIG 1

$$\text{Contrast Ratio} = \frac{\text{Surface Luminance with all white pixels}}{\text{Surface Luminance with all black pixels}}$$

Note4. Viewing angle is the angle at which the contrast ratio is greater than 10(CR≥10:1). The measurement instrument is DMS-803. For more information, please refer to FIG 1 and FIG 3.

Note5. CIE (x, y) chromaticity for CF only, measured with Olympus MHL-450 under C light.

FIG. 1 DMS-803 Measurement Set-Up

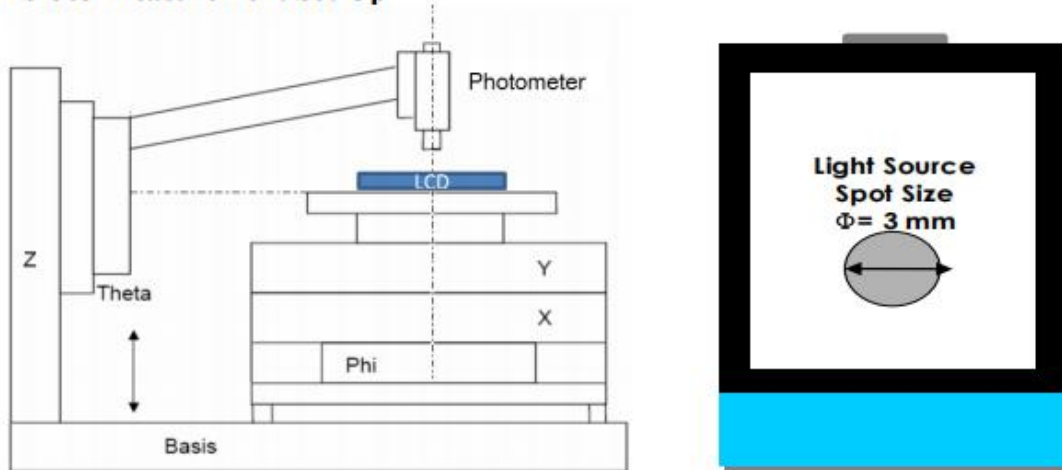

FIG. 2 The definition of Response Time

The response time is defined as the following figure and shall be measured by switching the input signal for “black” and “white”. This definition is valid for a normally black display. For a normally white display the opposite definition applies.]

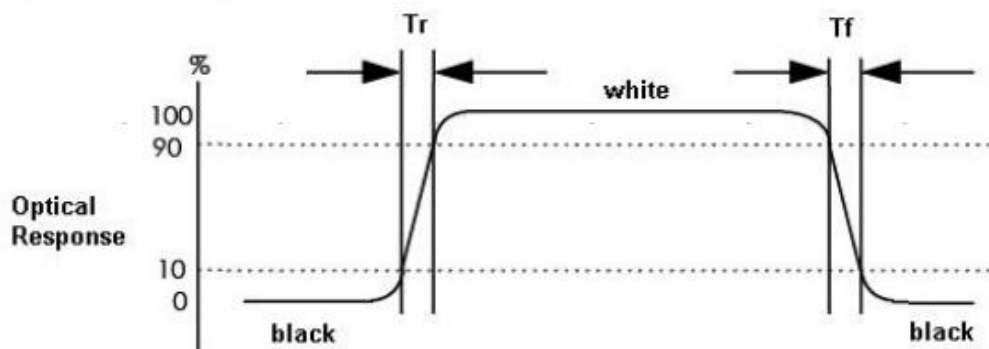
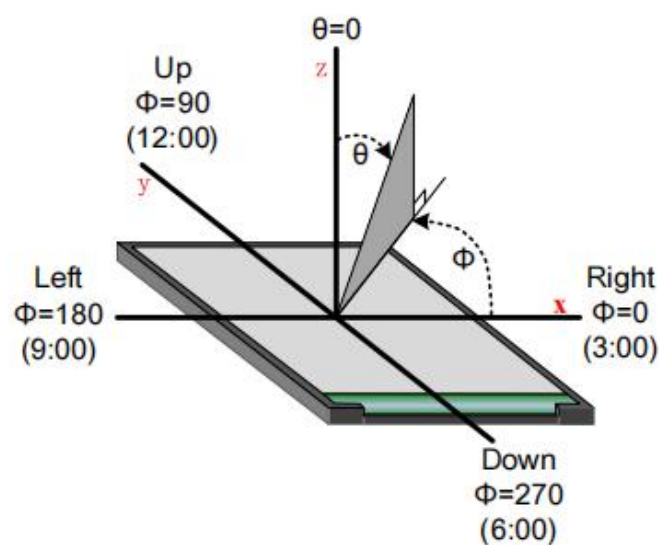

FIG. 3 The definition of viewing angle



Note(4) Backlight circuit

